



Part of the Railtech Architectural Group

# DIVIDE AND CONQUER

lightweight  
durable  
partitions  
with STC32

## Custom powerlift partitions

Skyfold Eclipse is a fully automatic custom built partition that redefines space. It is lighter than conventional systems and can be customized to suit just about any project. An excellent choice for educational institutions.

Creates space and  
a quieter environment

# STC32

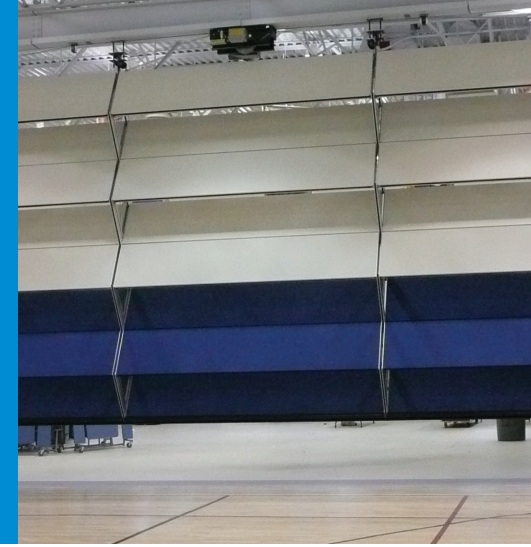

Up to 36 feet high (11 m).  
Virtually any length.  
Extremely durable.  
Built-in infrared safety system.

## DOWNLOAD REPORTS

SOUND TEST REPORTS (NORTH AMERICA)  
STC 32 Sound Transmission Loss Report

SOUND TEST REPORTS (INTERNATIONAL)  
31 Rw Sound Insulation Report

## KEY FEATURES AND BENEFITS

- ❖ Automatically retracts into the ceiling to reconfigure rooms and save floor space
- ❖ Extremely light weight: about 6.0 lbs/ft<sup>2</sup> (29.3 kg/m<sup>2</sup>)
- ❖ Quiet, effortless turnkey operation – no manual labor required
- ❖ Custom manufactured to meet your specific needs
- ❖ With an STC of 32, ideally suited to create a room barrier, from a school gymnasium to an airport baggage-claim area
- ❖ Available finishes include stainless steel, fabric, vinyl, melamine, wood veneer, paint, mesh\*, netting\*, grills\* and more.

\* These finishes will affect the STC rating.

## ECLIPSE PANEL DETAIL

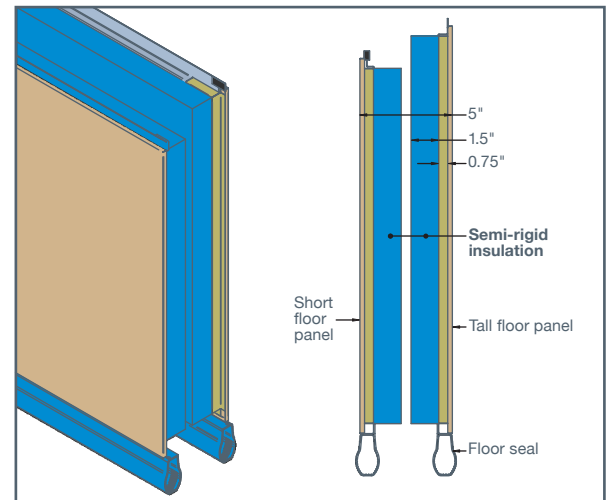

To learn about other available products, please visit us.

[www.skyfold.com](http://www.skyfold.com)



Part of the Railtech Architectural Group

For more information visit our website or contact us directly:

MAIN OFFICE

T 514 457-4767 F 514 457-7111 [info@skyfold.com](mailto:info@skyfold.com)  
325 Lee Avenue, Montreal, Quebec, CANADA H9X 3S3

[www.skyfold.com](http://www.skyfold.com)

